

COPPER WEAK BACK FERRULES (SOLDERING TYPE)

MATERIAL : ELECTROLYTIC HIGH CONDUCTIVITY-COPPER
FINISH : ELECTRO TINNED PLATED

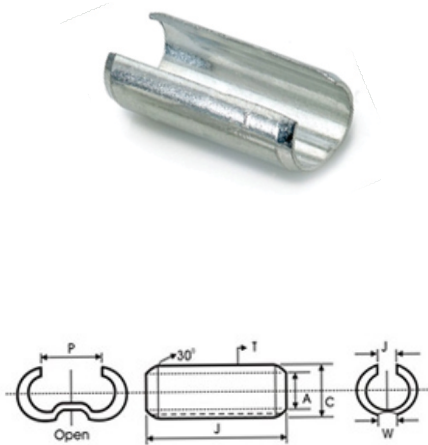

Product Ref.	Size mm ²	Dimensions mm					
		A	C	G	J	P	W
HGWB-F-6	6	3.0	4.6	2	20	3	-
HGWB-F-10	10	4.4	6.0	2	25	4	-
HGWB-F-16	16	5.5	7.5	2	25	5	1.5
HGWB-F-25	25	7.0	9.0	2	30	7	1.5
HGWB-F-35	35	8.0	10.4	2	35	8	1.5
HGWB-F-50	50	9.5	11.9	2	40	9	1.5
HGWB-F-70	70	12.0	14.8	3	45	12	3.0
HGWB-F-95	95	13.5	16.3	3	50	13	3.0
HGWB-F-120	120	15.5	18.7	4	55	15	3.0
HGWB-F-150	150	17.0	20.6	4	60	16	3.0
HGWB-F-185	185	18.5	22.9	4	65	18	5.0
HGWB-F-225	225	20.5	24.9	5	75	20	5.0
HGWB-F-240	240	22.0	26.4	5	80	21	5.0
HGWB-F-300	300	24.0	29.6	5	85	23	5.0
HGWB-F-400	400	28.5	34.7	7	95	27	5.0
HGWB-F-500	500	30.5	37.5	7	105	30	5.0
HGWB-F-625	625	34.5	42.5	8	115	33	5.0

MECHANICAL CABLE LUGS - BOLTED WITH 2 SCREWS OR 4 SCREWS

MATERIAL : BRASS
FINISH : ELECTRO TINNED PLATED
Steel Screws Electro Plated

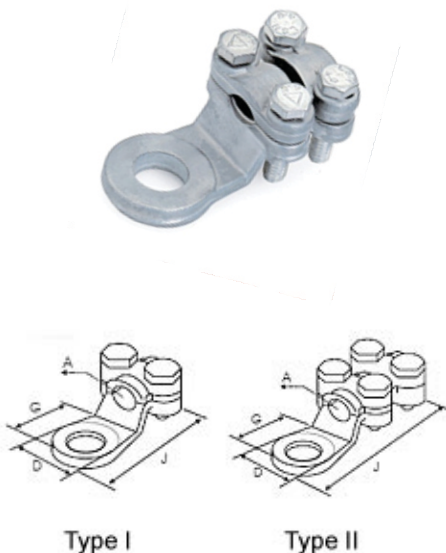

Product Ref.	Size mm ²	Dimensions mm					
		A	B	B	D	Screw	Type
HG2S-10	10	4.0	6.0	15.0	32.5	M-5	I
HG2S-16	16	5.1	8.5	17.0	37.0	M-5	I
HG2S-25	25	6.3	8.5	18.75	42.0	M-5	I
HG2S-35	35	7.5	10.5	21.50	4.0	M-5	I
HG4S-50	50	9.5	10.5	23.0	56.5	M-6	II
HG4S-75	75	11.0	13.25	26.0	61.0	M-6	II
HG4S-100	100	13.0	14.30	29.0	65.0	M-6	II
HG4S-120	120	14.0	14.80	32.0	71.0	M-6	II
HG4S-170	170	16.0	16.0	33.0	81.0	M-8	II
HG4S-200	200	17.0	17.0	35.0	85.0	M-8	II
HG4S-250	250	18.0	17.0	38.0	87.5	M-8	II
HG4S-300	300	21.0	19.8	45.0	118	M-10	II
HG4S-400/500	400/500	25.5	22.0	53.0	132	M-10	II
HG4S-700	700	34.0	22.0	60.0	150	M-10	II

(All Dimensions in mm)